

# TN266

## PCB Layout for the Ethernet PHY Interface

### Introduction

This technical note provides reference design information to allow you to design your own PCB with an Ethernet connection.

Figure 1 shows a typical wiring diagram for the differential pair of an Ethernet PHY device such as the Integrated Circuit Systems ICS1893BK, which integrates the RJ-45 jack and the magnetic module.

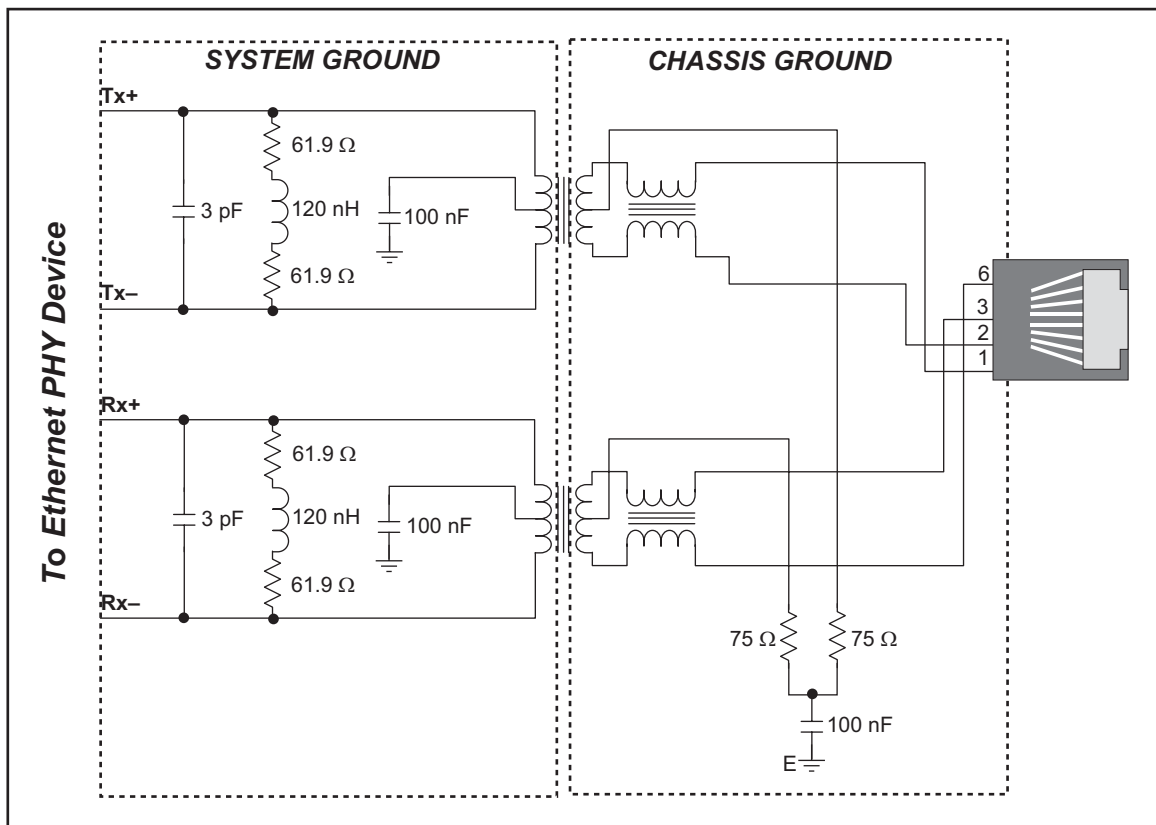

**Figure 1. Typical Wiring Diagram for Differential Pair**

The values of the components used will vary depending on the Ethernet PHY device you choose. Please refer to the data sheet and other information supplied by the manufacturer of your Ethernet PHY device for additional information on specific or recommended values.

## PCB Layout Recommendations

- Keep the traces between the magnetic module and the RJ-45 jack as short as possible — their length must be less than 25 mm (1 inch), and their impedance must be kept below 50  $\Omega$ . No vias or layer changes are allowed. A module that integrates the RJ-45 jack with the magnetic module is preferred.
- The Tx+/Tx- and Rx+/Rx- traces should always be as short as possible (less than 25 mm or 1"). If longer traces are absolutely required, the maximum length is limited to 75 mm (3"). The individual trace impedance of Tx+/Tx- and Rx+/Rx- must be kept below 50  $\Omega$ , and the differential characteristic impedance of the pair must be 100  $\Omega$ .
- Route each Tx+/Tx- and Rx+/Rx- pair together, keeping their separation under 0.25 mm (0.01"), using 0.25 mm (0.01") traces. Keep the Tx+/Tx- and Rx+/Rx- trace lengths as equal as possible.
- The separation between the Tx+/Tx- and the Rx+/Rx- differential pairs must be at least 0.5 mm (0.02"). It is best to separate them with a ground plane.
- Avoid any off-board wire assemblies. If wire assemblies are needed, use a twisted pair to connect Tx+/Tx- and Rx+/Rx-, and keep their length as short as possible., no more than 75 mm (3").
- Never use right-angle traces — use 45° angles or curves in traces.
- Trace widths should not vary.
- Use precision components (1 percent or better) in the line-termination circuitry.
- Ensure that the power supply is well regulated.

## Impedance and PCB Stacking

The trace impedance is affected by many factors such as the width of the trace, the thickness of the copper, the PCB material, the PCB stacking specification, and the spacing between the differential pairs. The Web sites listed below contain additional reference information.

- [Differential Impedance Calculator \(www.icd.com.au/Diff\\_Calc/diff\\_index.htm\)](http://www.icd.com.au/Diff_Calc/diff_index.htm) — registration required.
- [Saturn PCB Design, Inc. \(www.saturnpcb.com\)](http://www.saturnpcb.com)

For more precise design specifications, please contact your PCB foundry and request information on their impedance control processes.

You will need to know the *dielectric constant* and the *copper thickness* to calculate trace impedance.

### Dielectric Constant

The dielectric constant is different for different PCB materials, and may be different for the same type of the material, for example, FR-4. Contact your PCB foundry to obtain the exact dielectric constant for the material you choose.

## Copper Thickness

The copper in a PCB is rated in ounces, and represents the thickness of 1 ounce of copper rolled out to an area of 1 square foot. Table 1 shows a listing of the PCB copper thickness relative to its rating.

**Table 1. PCB Copper Ratings**

Weight	Thickness	
0.5 oz.	0.0007"	17 μm
1 oz.	0.0014"	34 μm
2 oz.	0.0028"	68 μm

Reproduced from [Daycounter Engineering Services](#) Web site.

For example, a PCB rated at 1 oz. copper has a copper thickness of 34 μm (0.0014").

## Additional Reference Information

Consult the User's Manuals for the Rabbit 5000 microprocessor or for your RabbitCore module for additional reference information. Your PCB foundry should be able to supply you with additional reference information relative to your design and their fab services.

**Rabbit — A Digi International Brand**

[www.rabbit.com](http://www.rabbit.com)