

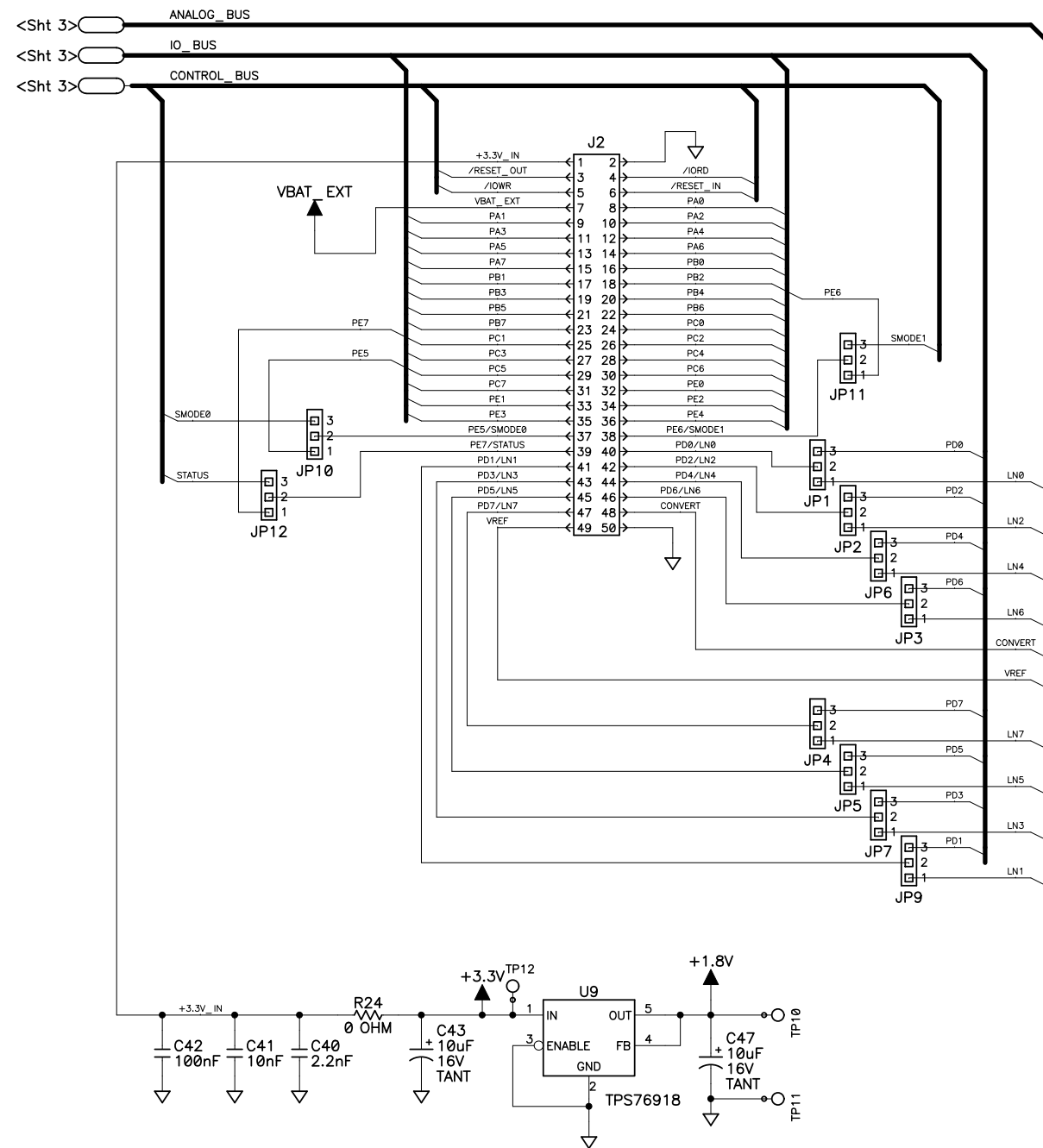

CORE HEADER



- NOTES: UNLESS OTHERWISE SPECIFIED;
1. ALL RESISTOR VALUES ARE IN OHMS, 1/16W, 1%
 2. THE ORIGIN SOURCE OF A VOLTAGE IS REPRESENTED BY (VCC), AND ALL REFERENCES TO THAT VOLTAGE ARE REPRESENTED BY (VCC).

 3. COMPONENT VALUES SHOWN WITH AN ASTERISK (*) FOLLOWING THE VALUE, MAY HAVE DIFFERENT VALUES, OR MAY NOT BE STUFFED. SEE STUFFING CHART FOR CLARIFICATION.

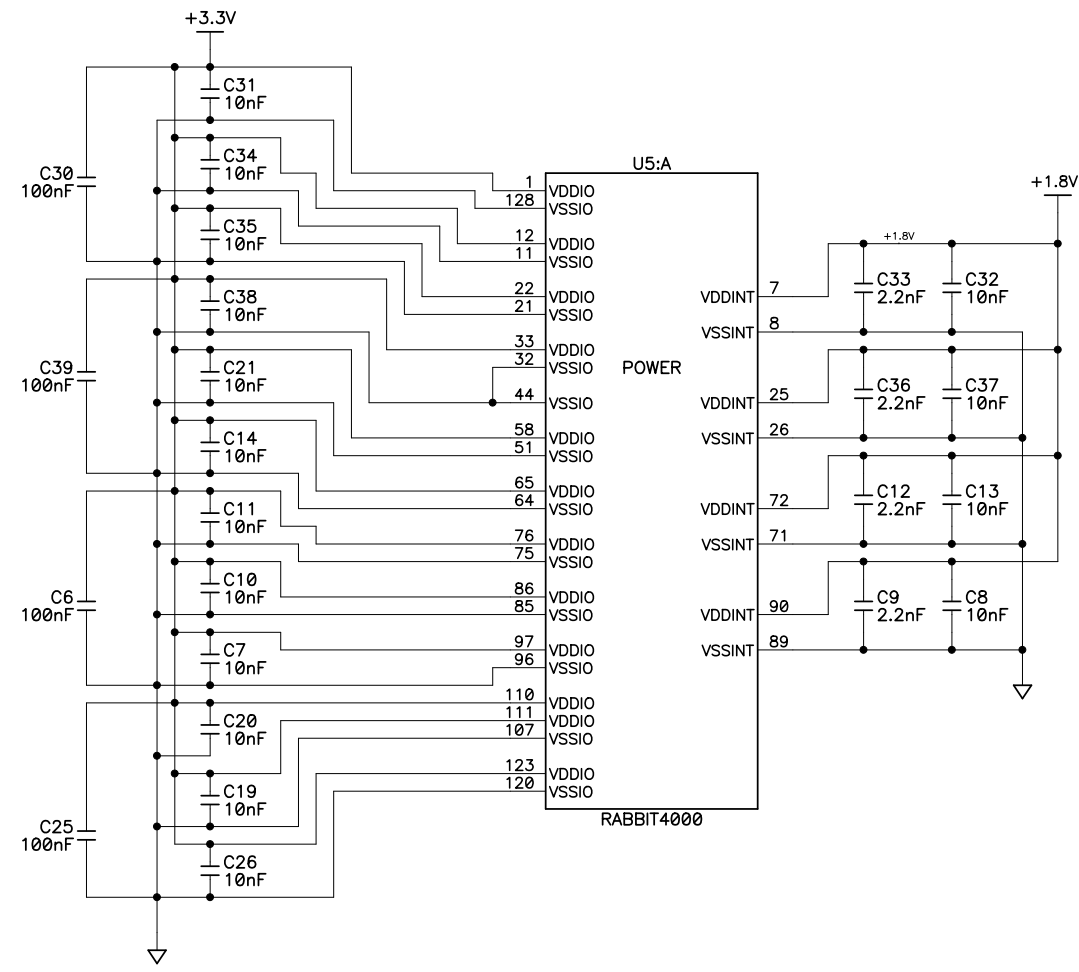
REVISION HISTORY			REVISION APPROVAL			
REV	ECO	DESCRIPTION	PROJECT ENGINEER	APPROVAL DATE	DOCUMENT CONTROL	APPROVAL DATE
A	E14326	INITIAL RELEASE	JC	2/10/06	KF	2/10/06
B	E14502	ADDED FAST SRAM	JC	4/28/06	KF	4/28/06
C	E14668	STUFFING TABLE UPDATE	JC	7/12/06	KF	7/11/06
D	E15009	ADD 4100 AND 4120 STUFFING OPTION TABLES	JC	1/16/07	KF	1/16/07
E	E15113	ADD RP1 INSTALLED AS DEFAULT, REVISED VOLTAGE REFERENCE AS VOLTAGE SOURCE ON PAGE 1	XT	3/19/07		
F	E15144	UPDATE PART REFERENCE AT U1/UPDATE SRAM PIN OPTIONS	XT	4/7/07		
G	001886	UPDATE STUFFING TABLE FOR PORT E	NH	2/26/10	KS	3/12/10

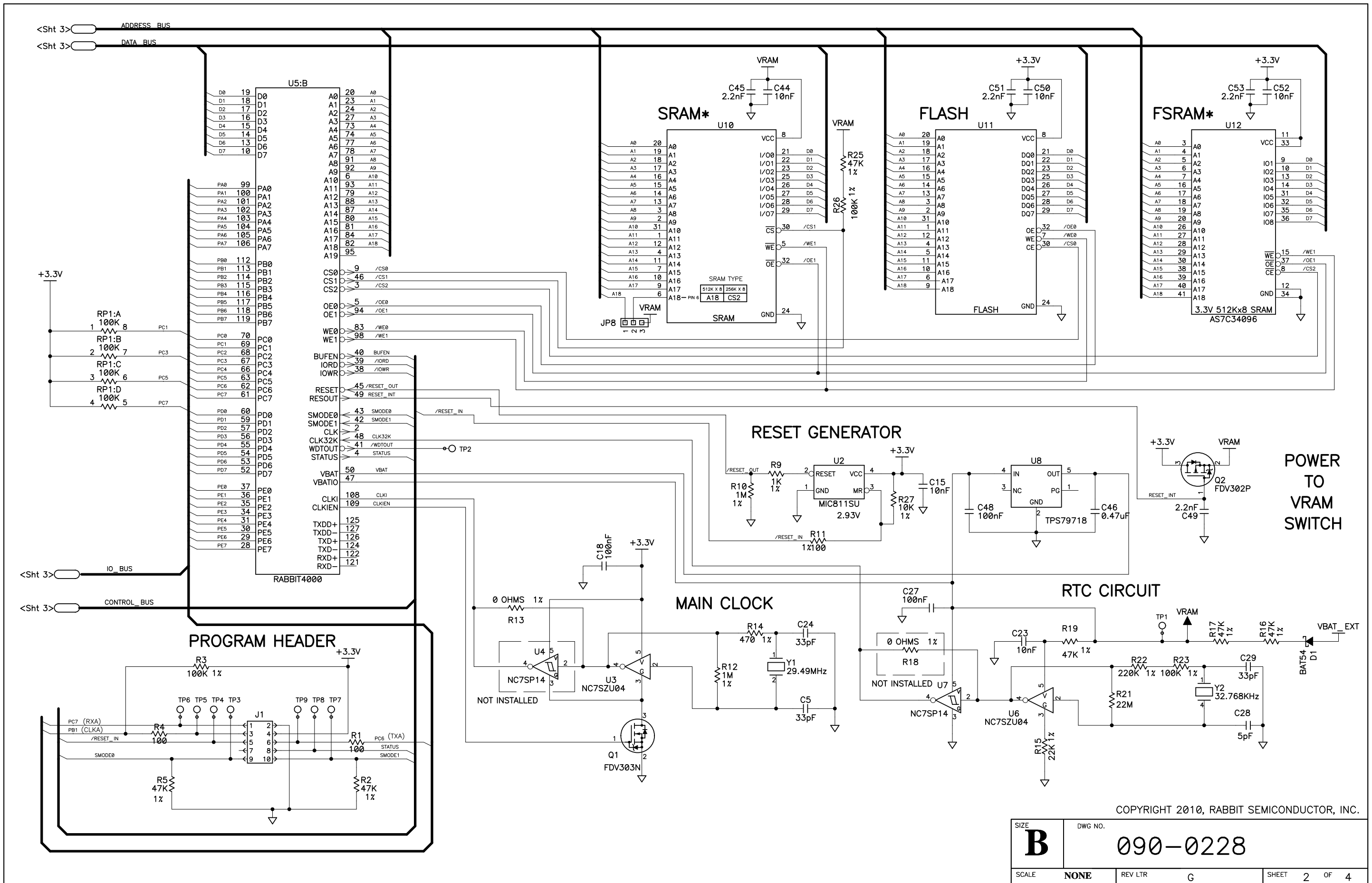

COPYRIGHT 2010, RABBIT SEMICONDUCTOR, INC.

APPEND THE FOLLOWING DOCUMENTS WHEN CHANGING THIS DOCUMENT:	DRAWING CONTENT:		TITLE SCHEMATIC DIAGRAM RCM41XX	 2900 SPAFFORD ST. DAVIS, CA 95616 530 - 757 - 4616
	DRAWN BY: (INITIAL RELEASE) J CAMPBELL			
	REVISED BY:			
	APPROVALS: INITIAL RELEASE			
	PROJECT ENGINEER: J CAMPBELL	02/10/06	SIZE B	DWG NO. 090-0228
	ENGINEERING MANAGER:		SCALE NONE	RELEASE DATE
	SIGNATURES	DATE	SHEET 1 OF 4	



COPYRIGHT 2010, RABBIT SEMICONDUCTOR, INC.

SIZE B	DWG NO. 090-0228
SCALE NONE	REV LTR G
SHEET 2 OF 4	

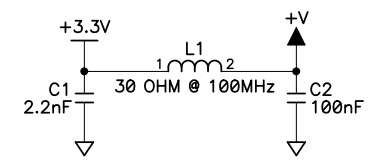
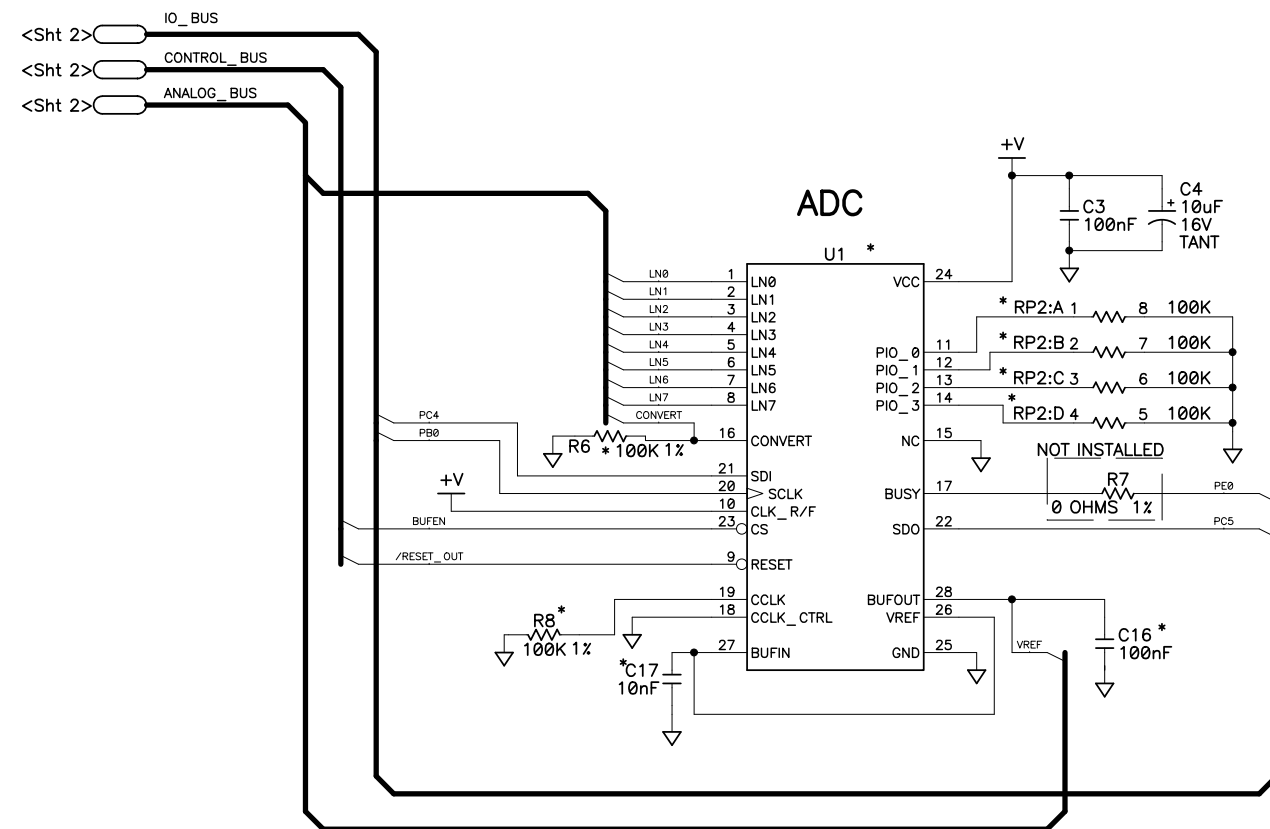

SIZE B	DWG NO. 090-0228
SCALE NONE	REV LTR G
SHEET 3 OF 4	

RCM41XX STANDARD CONFIGURATION OPTIONS			
OPTION	RCM4100	RCM4110	RCM4120
SRAM	512KB	256KB	512KB
FAST SRAM	512KB	NONE	512KB
FLASH	512KB	512KB	512KB
ADC	12 BIT	NONE	NONE
ALT SIGNALS	PORTE[5..7]	PORTE[5..7]	PORTE[5..7]

OPTION: SRAM			
PART	256KB	512KB	
U10	256KB INSTALLED	512KB INSTALLED	
JP8	0 Ohm (2-3)	0 Ohm (1-2)	

OPTION: FSRAM		
PART	NONE	512KB
U12	NOT INSTALLED	512KB INSTALLED
C52, C53	NOT INSTALLED	INSTALLED

OPTION: FLASH		
PART	512KB	
U11	INSTALLED	

OPTION: ALT SIGNALS (SELECTS PIN 37-39 FUNCTION, PORTE[5..7] or SMODE0, SMODE1, STATUS)		
PARTS	PORTE[5..7]	PROG SIGNALS
JP10, JP11, JP12	0 Ohm (1-2)	0 Ohm (2-3)

OPTION: ADC		
PART	NONE	12 BIT
U1	NOT INSTALLED	ADS7870
C1, C2, C3, C4 C16, C17	NOT INSTALLED	INSTALLED
L1	NOT INSTALLED	INSTALLED
R6, R8, RP2	NOT INSTALLED	INSTALLED
R7	NOT INSTALLED	NOT INSTALLED
JP1, JP2, JP3, JP4, JP5, JP6, JP7, JP9	0 Ohm (2-3)	0 Ohm (1-2)

CLOCK CONFIGURATIONS	
PART	
R13	INSTALLED
U4	NOT INSTALLED
R18	NOT INSTALLED
U7	INSTALLED

SIZE B	DWG NO. 090-0228
SCALE NONE	REV LTR G
SHEET 4	OF 4